

## Technology Offer

### Neutrino Detector

Ref.-No.: MI 0206-5384-BC

---

#### Abstract

This technology introduces an advanced neutrino detector system designed to detect neutrinos using cryogenic target crystals and veto detectors. The system employs a multi-layer detection approach that includes a target detector, an inner veto detector, and an outer veto detector, all operating at cryogenic temperatures. This configuration allows for high-sensitivity detection of neutrinos, even in above-ground environments. The technology is particularly suitable for monitoring nuclear power plants and other applications requiring precise neutrino detection with minimized background interference. The device's compact and mobile design enables flexible deployment in various settings, enhancing its utility in scientific research and environmental monitoring.

#### Advantages

- **High Sensitivity:** Detects neutrino interactions with a sensitivity threshold below 50 eV.
- **Background Suppression:** Inner and outer veto detectors minimize background noise from various radiation sources.
- **Compact Design:** Suitable for above-ground and mobile applications.
- **Scalability:** Can be expanded with arrays of target detectors for increased detection probability.
- **Versatility:** Operable in various environments, including nuclear power plants and geological sites.

#### Applications

- **Nuclear Power Plant Monitoring:** Real-time tracking of reactor activity and fuel composition.
- **Environmental Surveillance:** Detection of neutrino emissions from geological formations.
- **Scientific Research:** Fundamental studies in particle physics, particularly neutrino properties.
- **Dark Matter Searches:** Potential application in detecting low-mass dark matter particles.
- **Mobile Monitoring Systems:** Deployable on mobile platforms for flexible monitoring in different locations.

#### Background

Detecting neutrinos is inherently challenging due to their weak interactions with matter and lack of electrical charge. Traditional neutrino detectors rely on massive underground setups to minimize background noise, making them impractical for above-ground or mobile applications. Existing detectors also struggle with achieving the necessary sensitivity thresholds, particularly in environments exposed to cosmic radiation. This invention addresses these challenges by combining cryogenic detection with advanced veto systems to create a compact, high-sensitivity device capable of operating above ground. This

breakthrough enables new applications, including real-time monitoring of nuclear reactors and other sources of neutrinos.

## Technology

The core of the technology is a neutrino detector device comprising a target detector with a cryogenic target crystal, an inner veto detector, and an outer veto detector. The target crystal, made of materials like  $\text{CaWO}_4$ , generates phonons upon neutrino interactions, which are then detected by a temperature sensor (transition edge sensor). The inner veto detector, composed of single-crystal wafers (e.g., silicon or sapphire), surrounds the target detector to suppress background radiation from beta and alpha decays. The outer veto detector further reduces background noise from gamma and neutron radiation. This multi-layered structure achieves sensitivity thresholds below 50 eV, making it suitable for detecting coherent neutrino-nucleus scattering (CNNS) above ground.

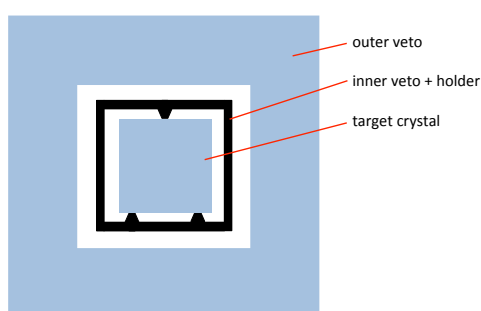

The neutrino detector includes three cryogenic detectors: a target crystal for detecting neutrinos, the outer veto for detecting neutrons and gammas, and the inner veto for detecting  $\alpha$ - and  $\beta$ -decays.

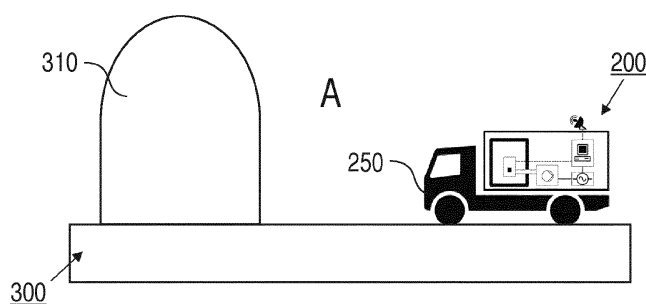

Monitoring a nuclear power plant 310 by means of the neutrino detector 200 mounted on a truck. Thereby the neutron detector is movable in the environment 300 of the nuclear power plant and measurements can be performed at a distance up to 500 m from the reactor core.

## Patent Information

EP3610299B1 (pending patents in DE, FR and GB),  
US10935674B2, JP6884228B2,  
CN110770603B

## Publications

R. Strauss et al., *The n-cleus experiment: A gram-scale fiducial-volume cryogenic detector for the first detection of coherent neutrino-nucleus scattering*, arXiv:1704.04320v2, 9 August 2017

## Contact

**Dr. Bernd Ctortecka**  
**Senior Patent- & License Manager, Physicist**  
Phone: +49 163 88 999 05  
Email: ctortecka@max-planck-innovation.de